

TECHNICAL DATA SHEET

EGGER PerfectSense lacquered boards

Material description:

Decorative, UV coated wood-based material.

Core board version as EGGER MDF ST E1

Use:

Decorative wood-based panels for interior uses.

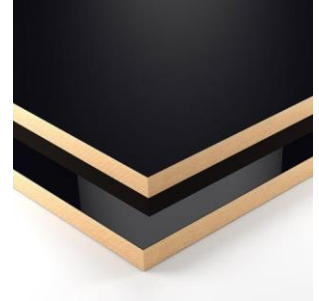

EGGER MDF ST E1 board type according to EN 622 type 5

Mechanical properties Average values boards	Unit	Board thicknesses		
	[mm]	>10 - 12	>12 - 19	>19 - 25
Density	[kg/m ³]	Specific to plant		
Internal bond strength EN 319	[N/mm ²]	>0.60	>0.55	>0.55
Bending strength EN 310	[N/mm ²]	>22	>20	>18
Modulus of elasticity EN 310	[N/mm ²]	>2500	>2200	>2100
Thickness swelling 24 h EN 317	[%]	<15	<12	<10
Surface soundness EN 311	[N/mm ²]	>1.0		
Screw withdrawal surface	[N]		>1080	>1080
Screw withdrawal edge	[N]		>900	>810
Sand content	[%]	<0.02		
Moisture content ^{*1)} EN 322	[%]	6±2		
Formaldehyde content ^{*2a)}	Class	E1		
Formaldehyde emission ^{*2b)}	Class	CARB 2		
Reaction to fire EN 13501-1	Class	D-s2,d0		

PerfectSense – General tolerances

	Test standard	Unit	Thickness range ^{*3)}		
			<15mm	15 up to 20mm	>20 mm
Thickness					
• with one-sided PerfectSense	EN 14323	[mm]	±0.3		
Length and width					
• commercial available size	EN 14323	[mm]	±5		
• cut-to-size boards			±2.5		
Flatness					
	EN 14323	[mm/m]	--	≤2 ^{*4)}	
Edge damage					
• commercial available size	EN 14323	[mm]	≤10		
• cut-to-size boards			≤3		

PerfectSense - surface properties

Quality feature	Test standard	Class	Value	Unit
Scratch resistance				
Gloss	DIN 68861-4 / DIN EN 15186	4C	≥1.5	[N]
Matt		4B	≥3	
Resistance to chemicals				
	DIN 68861-1 / DIN EN 12720	1B	-	-
Cross-cut				
	DIN EN ISO 2409	GT 0-1	-	-
Gloss level				
Gloss	EN ISO 2813	60°	92 ±5	GU
Matt		60°	3 ±2	GU
Resistance to dry heat				
	DIN 68861-7 / DIN EN 12722	7C	100	°C
		7B ^{*5)}	140	°C
Resistance to wet heat				
	DIN 68861-8 / DIN EN 12721	8B	70	°C
		8A ^{*5)}	100	°C
Abrasion resistance				
	DIN 68861-2	2B	> 350 to ≤ 650	WR
Light fastness				
	EN 15187		Blue scale ≥6 Grey scale >4	
Wet climate resistance ^{*6)}				
(Climate 40 ± 2 °C; relative humidity 85 ± 5%; duration 14 days)	AMK-MB-005, module 2	No gap forming or edge breaking		
Alternating climate resistance ^{*6)}				
(10 cycles: 1h Climate -20 ± 2 °C; 3h Climate 20 ± 2 °C / humidity 85 ± 5%; 3h Climate 60 ± 2 °C / humidity 55 ± 5%)	AMK-MB-005, module 3	No surface cracking, no discolouration, no gap forming or edge breaking		
Surface defects according to AMK-MB- 009				

On an even surface, defects must not be apparent at a distance of 0.7 m. Where surfaces without any defects cannot be realised, small flaws and irregularities in the surface are admissible. Surface defects are only those defects, which are greater than 1.0 mm² and are recognised when examining the surface at a distance of 0.7 m and an angle of view of about 30°. Maximum allowed is 1 defect/m².

The following framework conditions apply:

- Viewing distance: 700 mm
- Lighting intensity: 1000 – 2000 lx
- Inclination angle: 30° to the vertical
- Type of light (daylight, colour temperature) D 65: 6500 K
- Viewing duration: max. 20 seconds

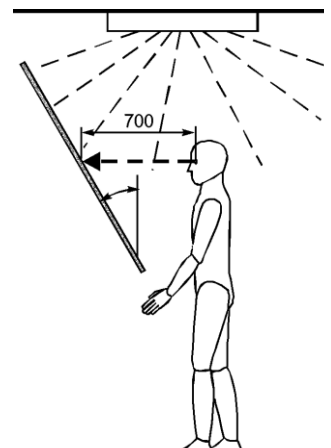

^{*1)} upon delivery

^{*2a)} formaldehyde content: According to the Regulation of Chemical Interdiction of October 1993 in connection with the DIBt Directive concerning the classification and monitoring of wood-based material boards with regard to formaldehyde emissions of June 1994, the Perforator threshold (photometric) of

uncoated chipboard may not exceed 8 mg HCHO/100g dry board for a material moisture of 6.5%. The moving six-monthly average is max. 6.5 mg HCHO/100g dry board. Perforator value according to DIN EN 120 as sliding six-monthly average.

- *2b) Examination in accordance with American test chamber. According to CARB (California Air Resources Board) requirements Table 1 § 93120.2 Phase 2 is fulfilled (≤ 0.11 ppm according to ASTM 1333 E).
- *3) relative to the nominal value
- *4) only with balanced construction of surfaces
- *5) with gloss surfaces slight gloss changes are permitted
- *6) refers to the surface coating

QUALITY FEATURES

The essential quality features of PerfectSense lacquered surfaces are described according to the above-mentioned table. For certain purposes, properties that are not part of this data sheet may be required. When necessary and upon request, they can be determined according to the relevant standards and specified testing procedures.

MATCHING COLOURS AND SURFACES

If the customer requires colour and surface coordination, only a slight deviation between original sample and test body is admissible. The test is subject to regulation AMK-MB 009 (table Surface defects).

GENERAL NOTES

Careful inspection of incoming goods is an essential part of proper order processing and is included in the EGGER Group's payment and delivery terms. EGGER recommends that this inspection is carried out using statistical processes. PerfectSense lacquered boards must be transported and stored with care. It is expedient to store the boards lying down on a flat, level and dry ground, with a cover board in a closed building. Otherwise, sealing is necessary to avoid the possible swelling of the edges. The room temperature should not exceed the range of 10°C to 50°C.

Note: PerfectSense lacquered boards protective film must be removed immediately after processing, but no later than 5 months after delivery to ensure residue-free removal of the film can. Foiled products shall not be exposed to direct sunlight (UV radiation).

FURTHER DOCUMENTS

Technical data sheet:
EGGER MDF-ST E1

Provisional note:

This technical data sheet has been carefully drawn up to the best of our knowledge. We accept no liability for any mistakes, errors in standards or printing errors. In addition, technical modifications may result from the continuous development of PerfectSense lacquered boards, as well as from changes to standards and public law documents. The contents of this technical data sheet should therefore not be considered as instructions for use or as legally binding.